



TECHNICAL BULLETIN

CH50

Wako Autokit CH50
Wako CH50 Calibrator
Wako Complement Control



CONTENTS

| | | |
|-----------|---|-------|
| A. | The Complement System | 1 |
| 1. | Historical Perspective | 1 |
| 2. | The Complement System | 1 |
| (1) | The classical activation pathway | 2 |
| (2) | The alternative activation pathway | 2-3 |
| (3) | The membrane attack pathway | 3 |
| B. | The Biological Effects of Complement Activaton | 4 |
| 1. | Pro-Inflammatory Effects of Complement Activation | 4 |
| (1) | Anaphylaxis | 4 |
| (2) | Chemotaxis | 4 |
| (3) | Leucocytosis | 4 |
| (4) | Neutrophil activation | 4 |
| (5) | Cell lysis/cell activation | 4 |
| 2. | Complement-Derived Opsonic Activity | 5 |
| 3. | Immune Complex Solubilization | 5 |
| C. | Complement Measurement | 6 |
| 1. | Assays of Complement Activity | 6 |
| 2. | Hemolytic Assay | 6 |
| (1) | Mayer's method | 6 |
| I) | Definition of CH50 unit | 7 |
| II) | Calculation | 7 |
| III) | One-point method | 8 |
| IV) | Reagents | 8 |
| V) | Procedure | 8 |
| (2) | Modified Mayer's method | 9 |
| I) | Assay | 9 |
| II) | Results | 9 |
| III) | Calculation | 10 |
| (3) | Kent-Fife method | 11 |
| I) | Definition of CH50 unit | 11 |
| II) | Reagents | 11 |
| III) | Procedure | 11 |
| 3. | Liposome Immunoassay (LIA) | 12 |
| (1) | Liposomes | 12 |
| (2) | Wako Autokit CH50 test | 12-18 |
| 4. | Specimen | 19 |
| 5. | Cold Activation | 19 |
| D. | Clinical Significance | 20 |
| 1. | Reduced Total Complement Activity | 21-22 |
| 2. | Elevated Total Complement Activity | 23 |
| | References | 23 |

A. The Complement System¹

1. Historical Perspective

In the late 19th century scientists were trying to find out how the body defends itself against microorganisms. The Cellular Theory of Metchnikoff that cells in the blood attack and ingest invading bacteria was widely accepted. Buchner and others demonstrated that there was a heat-labile factor capable of destroying bacteria. Buchner named the factor *alexin* (Greek, *without a name*). Then, Bordet showed that this humoral bacteriolysis required two factors, a heat-stable factor present only in immune serum and a heat-labile factor present also in nonimmune serum. Meanwhile, Paul Ehrlich examined erythrocyte hemolysis by immune serum and confirmed the requirement for two factors. He called the heat-stable factor immune body (antibody) and the heat-labile factor *complement* to indicate that this factor complemented the immune body upon hemolysis and bacteriolysis.

2. The Complement System

The complement system is composed of at least 20 proteins. The complement proteins are numbered from C1 to C9, with the exception of C4, numbering is in the order of their reaction. They are able to interact sequentially with antigen-antibody complexes and with cell membranes. The whole process is controlled by the very short life of many of the intermediates and by the presence of regulators. The known component and control proteins of the system are listed in Table 1. The system is divisible into three interacting pathways, the classical and alternative activation pathways and the membrane attack pathway. (Fig. 1)

Table 1. The protein of the human complement system

| | Component | Molecular weight (kDa) | Plasma concentration (mg/dL) |
|-------------------------|-----------|------------------------|------------------------------|
| Classical pathway | C1q | 460 | 80 |
| | C1r | 83 | 50 |
| | C1s | 83 | 50 |
| | C4 | 205 | 600 |
| | C2 | 102 | 20 |
| Alternative pathway | Factor B | 93 | 210 |
| | Factor D | 24 | 2 |
| | Properdin | 220 | 26 |
| Common | C3 | 185 | 1300 |
| Membrane attack pathway | C5 | 190 | 70 |
| | C6 | 120 | 65 |
| | C7 | 110 | 55 |
| | C8 | 150 | 55 |
| | C9 | 69 | 60 |
| Control | C1-INH | 110 | 200 |
| | C4bp | 500 | 250 |
| | Factor H | 150 | 450 |
| | Factor I | 80 | 35 |

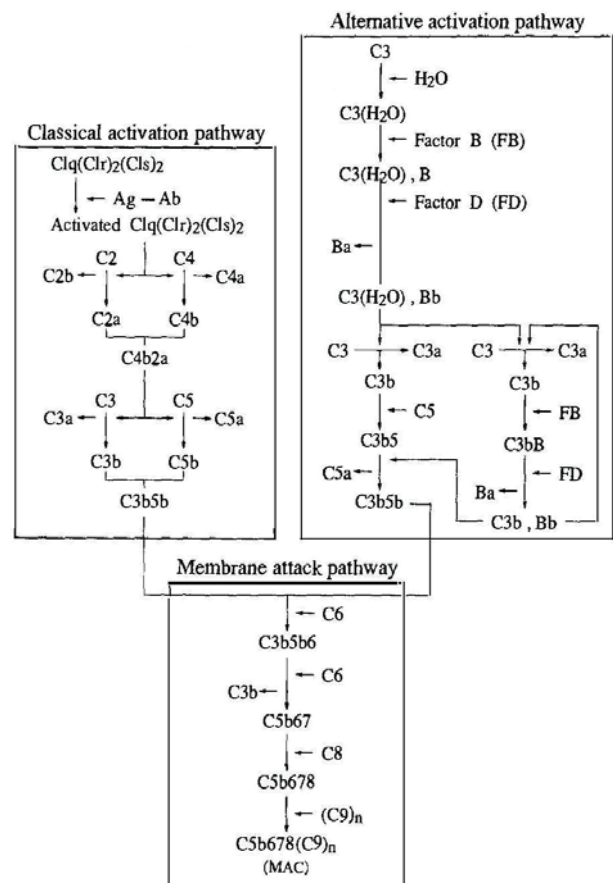

Fig 1. The complement system.

(1) The classical activation pathway

The classical pathway is initiated by antigen-antibody complexes. The first component of complement, C1, is composed of three subunits, C1q, C1r and C1s. One molecule of C1q and two molecules each of C1r and C1s are noncovalently linked to make the C1 complex. The association of the components requires calcium ions. Binding of C1q to immunoglobulin results in activation of the C1 complex. The activated C1 cleaves C4. The cleavage produces C4a and C4b. The small fragment, C4a, is released as an anaphylatoxin and the larger fragment, C4b, acquires binding sites capable of interacting with membranes. This newly exposed membrane binding site allows covalent binding of C4b to surfaces. C4b also possesses a site which binds C2 in the presence of magnesium ions. C2 bound to C4 is cleaved by the activated C1.

The smaller fragment, C2b, is released and the larger fragment, C2a, remains associated with C4b. The C4b2a complex is the classical-pathway C3 convertase, which catalyses cleavage of C3 in the next stage. The C4b2a complex cleaves C3 releasing a small fragment, C3a, which is an anaphylatoxin. The large fragment, C3b, acquires a binding site resulting in covalently binding membranes. C3b provides a binding site for C5. The bound C5 is cleaved by C4b2a releasing a small fragment, C5a, which has anaphylactic and chemotactic properties. The larger fragment, C5b, remains bound C3b. The classical activation pathway is represented schematically in Fig. 2.

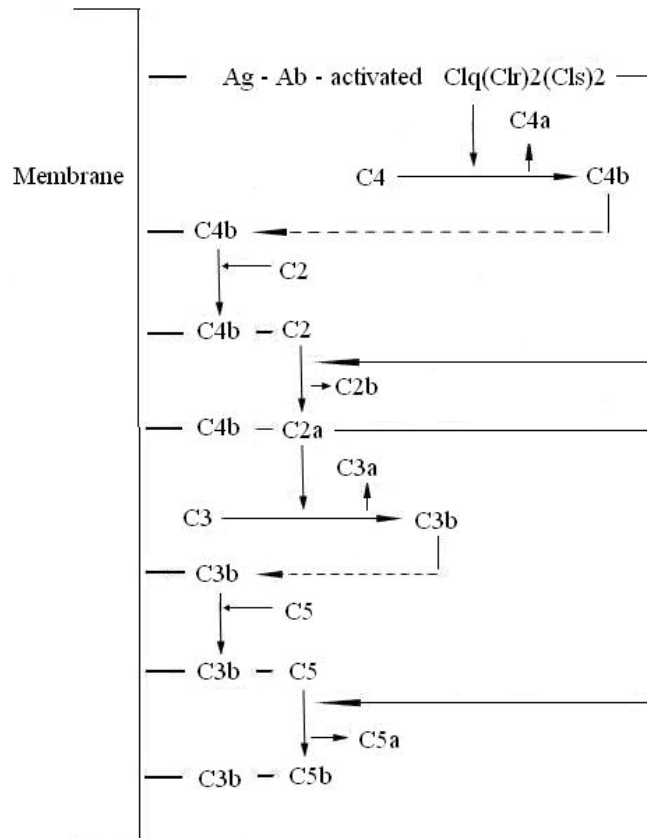

Fig. 2. The classical activation pathway.

(2) The alternative activation pathway

The alternative pathway provides a nonspecific natural defense system against microorganisms and other pathogens. Phylogenetically it is an older system than the classical pathway, an activity analogous to the alternative pathway being present in some primitive animals which have no antibody-activated complement equivalent. The first stage of the alternative pathway is that C3 is cleaved by activated C3. Then, how is the first C3 molecule activated? The 'tick-over' hypothesis, which was proven to be true by recent studies, explained that C3 is continuously undergoing low-grade spontaneous activation. C3 is activated by the spontaneous hydrolysis of its internal bond to form C3(H₂O), which is not able to bind to surfaces, but is functionally equivalent to C3b. C3(H₂O) binds Factor B in the presence of magnesium ions. Factor B bound to C3(H₂O) is cleaved by Factor D releasing a fragment, Ba, which may have mitogenic activity. The spontaneously generated convertase C3(H₂O), Bb cleaves C3 releasing the anaphylatoxin C3a and exposing the binding site on C3b. C3b nonspecifically binds to any surfaces of host cells and pathogenic organisms alike. C3b bound to nonactivating surfaces (e.g. host cells) is inactivated by the control proteins Factor H and I, whereas C3b bound to activating surfaces is protected from these factors and therefore persists.

The properties of a surface determining whether the activation occurs are not fully resolved. C3b on the cell surface binds Factor B in the presence of magnesium ions. Factor B bound to C3b is cleaved by Factor D. The bound C3b, Bb complex can then cleave more C3, generating more C3b on the surface. C3b binds C5 and the adjacent C3b, Bb complex cleaves C5 releasing C5a. The larger fragment, C5b, remains bound to C3b. The alternative activation pathway is represented schematically in Fig. 3.

(3) The membrane attack pathway

C5b bound to C3b expresses binding sites for membranes and for C6. Binding of C6 creates a complex with binding sites for membranes and for C7. Binding of C7 causes the complex to be released from C3b exposing a membrane binding site. Once C5b67 binds to membrane, the complex is stable and resistant to removal from the cell surface. C8 binds to C5b in the C5b67 complex. Incorporation of C8 into the C5b67 complex causes the complex to become more deeply embedded in the membrane. Binding of C9 to C8 forms the C5b6789, which is referred to as the membrane attack complex (MAC), and causes the MAC to be inserted deeply into the membrane. One of hypotheses is that the composition of MAC is C5b678(9)_n, where *n* is any number from 1 to 12. According to electron microscopic observation and other evidence, the MAC has cylindrical structure with a pore. The MAC is inserted deeply into the membrane and forms functional pores. Ions and small molecules can pass through the pores. Because of the high intracellular osmotic pressure, formation of a transmembrane channel allows water, ions and small molecules to flow into the cell, causing cell swelling and, as the result, cell lysis. The membrane attack pathway is represented schematically in Fig. 4.

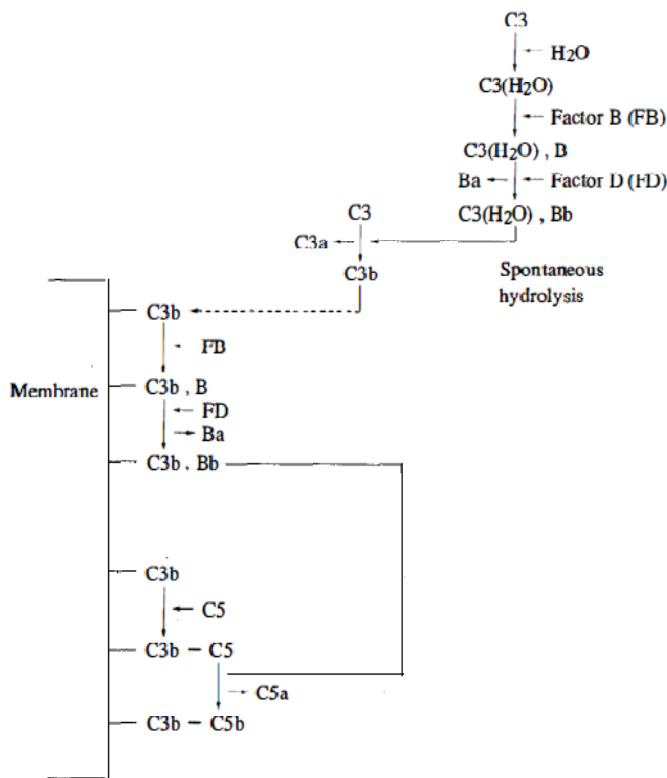

Fig. 3. The alternative activation pathway.

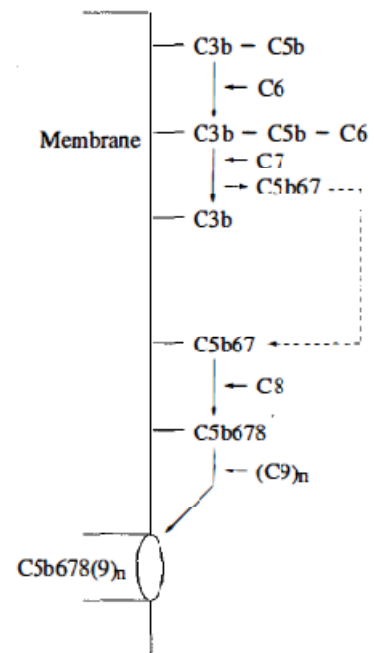

Fig. 4. The membrane attack pathway.

B. The Biological Effects of Complement Activation¹

1. Pro-Inflammatory Effects of Complement Activation

Tissue injury causes an inflammatory reaction, which leads to vasodilation, increases capillary permeability, and induces migration of phagocytic cells. One of symptoms of inflammation, swelling occurs due to fluid leakage caused by the increased permeability. Complement activation at the site of injury is a major mediator of these effects.

(1) Anaphylaxis

In the course of the complement activation pathway, anaphylactic peptides such as C3a, C4a and C5a are released. These peptides bind to specific receptors on the mast cell surface and stimulate the release of active products from mast cells in the tissues. The reaction, known as anaphylaxis, is caused by the release of histamine and other active molecules from the mast cells.

(2) Chemotaxis

Chemotaxis is the process by which cells are induced to migrate in a specific direction along a concentration gradient of a substance present in their environment. Substances derived from complement such as C3a and C5a act as chemotactic factors. Activation of complement at the site of inflammation results in the production of several factors which can stimulate neutrophil chemotaxis. The neutrophil response to a chemotactic signal is an essential part of host defense.

(3) Leucocytosis

A leucocytosis, which is caused in response to inflammation or infection, is an increase in the number of circulating white cells. Complement-derived factors mobilize leucocytes from their depots into the inflammatory site.

(4) Neutrophil activation

Neutrophils move up the C5a concentration gradient towards the inflammatory site. Once there, neutrophils are stimulated by C5a and release active molecules, which contribute to destruction of the initiating stimulus. This provides an important and efficient mechanism of host defense.

(5) Cell lysis/cell activation

The membrane attack complex (MAC) is a cell lysing agent. At the inflammatory site complement activation occurs. MACs are deposited on the surfaces of the invading organisms to lyse and remove them. Nucleated cells are, however, resistant to lysis, and formation of MACs on these cells may cause cell stimulation. Host cells in close proximity to the activation site will also have small amounts of MACs deposited on their surfaces. MACs induce the production and release of inflammatory mediators from a variety of cell types. Stimulation of cells at the inflammatory site by MACs may therefore cause further enhancement of inflammation.

2. Complement-Derived Opsonic Activity

Opsonization is the process by which foreign organisms or particles are rendered more easily ingestable by phagocytes. The process involves the coating of target particles with proteins, which the phagocytic cell can then recognize and bind via specific membrane receptors. These coating, proteins called opsonins are the bound fragments of C3 and C4 which are generated during complement activation.

3. Immune Complex Solubilization

Antigen is bound by antibody in the circulation to form immune complexes. This association of antibody with antigen initiates classical-pathway activation. Binding of complement to the immune complex interferes with formation of large, insoluble complexes, thereby rendering it more soluble. Solubilization of preformed complexes requires participation of both the classical pathway and the alternative pathway. This results in deposition of much larger amounts of complement (C3b) over the entire surface of the complex. Binding of C3b disrupts the antigen-antibody lattice by intercalating into the lattice thereby breaking primary antigen-antibody bonds.

C. Complement Measurement

1. Assays of Complement Activity

There are two types of complement assays, functional assay and protein content assay. A functional assay which measures the activity of the whole complement system is of importance in diagnosis of complement related diseases. Once complement components are activated, they are consumed in the cascade reactions or they are irreversibly inactivated in the fluid phase, so that the activated complement components no longer exhibit activity in the assay. The total complement activity assay measures the total activity or complement components remaining unactivated in the fluid phase.

Measurement of functional complement activity

Hemolytic assays have been the cornerstone of complement measurement for over 50 years. Classical pathway activity in serum is usually assessed by measurement of lysis of antibody-sensitized sheep erythrocytes. The amount of test serum required to cause 50% hemolysis of the erythrocytes is defined as the relative activity (CH50). Recently, a number of technical improvements on the standard hemolytic assays have been described. Further, attempts have been made to remove the requirement for animal erythrocytes, which can vary greatly from batch to batch and have very short expiration. In particular, a method has been developed by Wako which measures complement lytic activity by determining the increase of NADH released from liposomes coated with antigen. The liposome lysis assay is highly sensitive and the reagents are very stable, offering potential advantages over traditional hemolytic techniques.

2. Hemolytic Assay

Total complement activity in serum is usually assessed by measurement of lysis of sheep erythrocytes sensitized with anti-sheep erythrocyte antibody from rabbit. The antibody is combined with antigen on the surface of the sheep erythrocytes. There has been various proposals for the hemolytic method. However, after Mayer et al. reported the detailed study on assay conditions of total complement activity, the Mayer's method has been recognized as a reliable method and is widely used as the standard method.

(1) Mayer's method²

In the past, hemolytic complement activity has been estimated usually in terms of the smallest amount of fresh serum, which will produce complete lysis of sensitized red cells. However, in recent years there has been increased recognition of the advantage of 50% hemolysis as the endpoint. Studies of the region of partial hemolysis have shown that the relation between the amount of complement used and the proportion of cells lysed is non linear, but follows a sigmoidal curve, as shown in Fig. 5. It is evident from the shape of this curve that complete (100%) hemolysis is approached only gradually, and thus, relatively large increases in complement are required to effect lysis of the last 5 to 10% of the cells. In the central region, however, the curve is steep, and the degree of lysis is sensitive to small changes in the amount of complement. For precise measurement of the hemolytic activity of complement, the endpoint is therefore chosen in the central part of the sigmoidal response curve, usually at 50%.

I) Definition of CH50 Unit

The hemolytic unit of complement, CH50, is defined as that amount in milliliters which will lyse 2.5×10^8 optimally sensitized red cells out of a total of 5×10^8 cells in one hour's incubation at 37°C in a total volume of 7.5 mL.

II) Calculation

For mathematical description of the sigmoidal response curve of the hemolytic reaction, the equation of von Krogh

$$x = K \left(\frac{y}{1-y} \right)^{1/n} \quad [1]$$

has been commonly employed. In this relation, x represents the amount of complement (expressed in mL of diluted serum) and y stands for the degree of lysis (i.e., $100y =$ per cent hemolysis). The constant K is the 50% unit of complement, since at this point $y = 0.5$, and the term $y/1-y$ = unity, and therefore $x = K$. The magnitude of the exponent, $1/n$, which determines the shape of the sigmoidal curve, depends on experimental conditions, but, usually, a value of 0.2 ± 0.02 is applicable.

Logarithmic transformation of the von Krogh equation furnishes a function which is convenient for evaluation of experimental results:

$$\log X = \log K + \frac{1}{n} \log \left(\frac{y}{1-y} \right) \quad [2]$$

If $\log x$ is plotted against $\log (y/1-y)$, equation [2] describes a straight line of intercept $\log K$ and slope $1/n$, as shown in Fig. 6. By plotting experimental results according to [2], one obtains K , which is the quantity of complement required for 50% lysis, i.e., CH50, as well as $1/n$, which furnishes a check on the validity of the measurement.

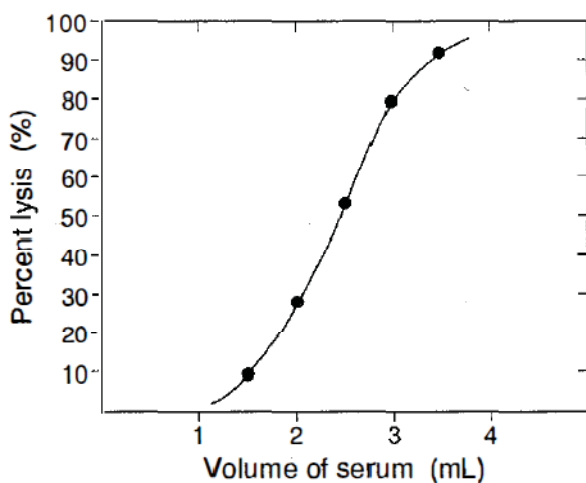

Fig. 5. Percentage of hemolysis of sensitized sheep erythrocytes plotted as a function of the volume of diluted complement.

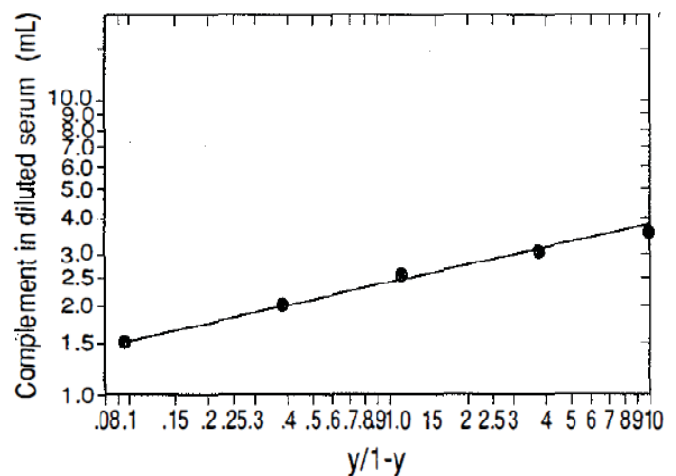

Fig. 6. Hemolysis of sensitized sheep erythrocytes by complement. Logarithmic plot of x against $y/1-y$, where $x =$ mL of diluted complement and $y =$ degree of lysis. Ordinate = x . Abcissa = $y/1-y$.

III) One-point method

Sometimes, only a single experimental point in the region of partial lysis is available, and in this event, the 50% unit can be calculated, provided the value of $1/n$ is known. If the measurements are conducted under conditions where $1/n = 0.2$, such single point analyses may be evaluated with the aid of the conversion factors given in Table 2. These factors are obtained as follows: If the amount of complement required for 50% lysis is assigned the value 1, and if $1/n = 0.2$ is substituted in equation [1] the expression

$$x = \left(\frac{y}{1 - y} \right)^{0.2} \quad [3]$$

is obtained, which relates x , the amount of complement giving any degree of lysis (y) to 1, the quantity of complement required for 50% lysis. The conversion factors given in Table 2, represent the values of x for the range $y = 0.10$ to $y = 0.90$. The use of these conversion factors may be illustrated as follows:

For example, if 1.0 mL of a 1/40 dilution of complement produces 30% lysis (i.e., $y = 0.30$), the number of CH50 per mL of undiluted complement equals $40 \times 0.844 = 34$ units.

Table 2. Conversion factors calculated from the von Krogh equation for $1/n = 0.2$.

| Degree of lysis | Factor | Degree of lysis | Factor |
|-----------------|--------|-----------------|--------|
| 0.10 | 0.644 | 0.55 | 1.041 |
| 0.12 | 0.671 | 0.60 | 1.084 |
| 0.14 | 0.696 | 0.65 | 1.132 |
| 0.16 | 0.718 | 0.70 | 1.185 |
| 0.18 | 0.738 | 0.75 | 1.246 |
| 0.20 | 0.758 | 0.80 | 1.320 |
| 0.25 | 0.803 | 0.82 | 1.354 |
| 0.30 | 0.844 | 0.84 | 1.393 |
| 0.35 | 0.884 | 0.86 | 1.438 |
| 0.40 | 0.922 | 0.88 | 1.490 |
| 0.45 | 0.961 | 0.90 | 1.552 |
| 0.50 | 1.000 | | |

IV) Reagents

- (a) Diluent.
Gelatin veronal buffer, pH 7.5, containing $MgCl_2$ and $CaCl_2$.
- (b) Sensitized cells.
Sheep erythrocytes suspension, 1×10^9 cells/mL, is mixed with an equal volume of hemolytic antibody solution (anti-sheep erythrocyte antibody from rabbit).

V) Procedure

Mix the reagents and samples by the following sequence.

- 1) 1.0 mL sensitized cells.
- 2) The amount of diluent required to make the final reaction volume of 7.5 mL.
- 3) The desired volume of an appropriate dilution of sample.

Incubate the reaction mixture at 37°C for 60 minutes with occasional mixing. Each set of measurements should include the cell blank as well as the complete (100% lysis). At the end of the incubation period, the tubes are centrifuged to remove unlysed cells and the clear supernatant fluids are analyzed photometrically for hemoglobin at a wavelength of 541 nm in a spectrophotometer. The fraction of cells lysed in each tube is calculated by dividing its absorbance value by the absorbance of the complete (100% lysis). It is convenient to represent results graphically by plotting $\log (y/1 - y)$ against $\log x$. Read the 50% lytic dose of complement from the graph. The complement activity is defined as the number of CH50 contained in 1 mL of undiluted serum. For example, if 4.0 mL of a 1/120 dilution of serum are required for 50% hemolysis, the activity equals 30 CH50 units per mL.

(2) Modified Mayer's method

There are occasions when it is desirable to scale down the complement measurement procedure. The technique described above is recommended from the standpoint of accuracy of pipetting and photometric analysis, but if desired, measurements can be performed in small reaction systems. Results will be the same, provided all reagents are scaled down proportionately. In the original Mayer's method 1 mL of 5×10^8 /mL of erythrocytes and a diluted serum sample is mixed in a total volume of 7.5 mL in a test tube. In the most widely used scale-down method, which is called modified Mayer's method or Mayer's 1/2.5 method, 0.4 mL of 5×10^8 /mL of erythrocytes and a diluted serum sample is mixed in a total volume of 3.0 mL in a test tube.

An assay example of modified Mayer's method

I) Assay

| | Sample | | | | | | Control | |
|----------------------------------|--------|-----|-----|-----|-----|-----|---------|--------|
| Test tube number | 1 | 2 | 3 | 4 | 5 | 6 | BL | 100% |
| GVB (mL) | 1.1 | 1.6 | 1.8 | 1.9 | 2.0 | 2.1 | 2.6 | DW 2.6 |
| Diluted serum ^{*1} (mL) | 1.5 | 1.0 | 0.8 | 0.7 | 0.6 | 0.5 | - | |
| EA ^{*2} (mL) | 0.4 | 0.4 | 0.4 | 0.4 | 0.4 | 0.4 | 0.4 | 0.4 |

↓
Incubate at 37°C for 60 min.

↓
Centrifuge.

↓
Measure absorbance of the supernatant at 541 nm.

BL: blank

GVE: gelatin veronal buffer

DW: distilled water

*1: 70-fold diluted serum sample

*2: sensitized sheep erythrocytes, 5×10^8 cells/mL

II) Results

| | Sample | | | | | | Control | |
|------------------|--------|-----|-----|-----|-----|----|---------|------|
| Test tube number | 1 | 2 | 3 | 4 | 5 | 6 | BL | 100% |
| Absorbance | 635 | 493 | 321 | 186 | 114 | 58 | 5 | 664 |

Absorbance: $\times 10^3$

III) Calculation

| | Sample | | | | | |
|------------------|--------|-------|-------|-------|-------|-------|
| Test tube number | 1 | 2 | 3 | 4 | 5 | 6 |
| Absorbance | 635 | 493 | 321 | 186 | 114 | 58 |
| BL | 5 | 5 | 5 | 5 | 5 | 5 |
| Abs-BL | 630 | 488 | 316 | 181 | 109 | 53 |
| y | 0.956 | 0.741 | 0.480 | 0.275 | 0.165 | 0.080 |
| y/1 - y | 21.7 | 2.86 | 0.923 | 0.379 | 0.198 | 0.087 |

y: hemolysis ratio

$$\log x = \log K + 1/n \log (y/1 - y),$$

where x is volume of diluted serum in mL and y is hemolytic ratio. The volume of diluted serum at y = 0.5, which means 50% hemolysis, can be read on the y axis against y/1 - y = 1 in the log-log graph. In the above example the volume is read as 0.82 mL. The 0.82 mL of the diluted serum hemolyzed 50% of the erythrocytes in 3mL of the reaction mixture. Since 0.82 mL of 70-fold diluted serum holds 1 CH50 unit, CH50 units in 1 mL of the neat serum is 85.4 as calculated below.

$$0.82 \text{ mL}/70 : 1 \text{ unit} = 1 \text{ mL} : A \text{ units}$$

$$A = 70/0.82 = 85.4$$

This value is obtained by Mayer's 1/2.5 method and should be converted to the units by original Mayer's method. The 85.4 is divided by 2.5, resulting in 34.2. Total complement activity of the sample is 34.2 CH50 units/mL.

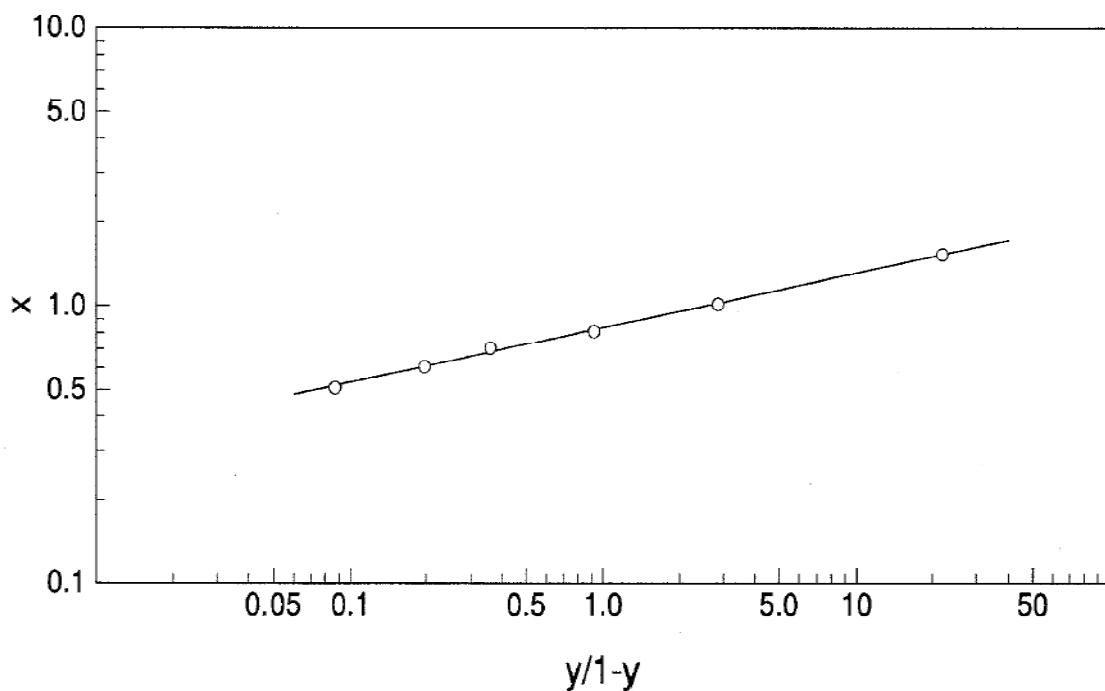

Fig. 7. Logarithmic plot of x against y/1 - y.



(3) Kent-Fife method³

I) Definition of CH50 unit

The CH50 unit is the volume required to lyse half the cells in 0.30 mL of optimally sensitized erythrocytes in 30 minutes at 37°C.

II) Reagents

- (a) Diluent.
Triethanolamine-buffered saline solution (TBS), pH 7.35, containing MgCl₂ and CaCl₂.
- (b) Sensitized cells.
Sheep erythrocytes suspension, 1 x 10⁹ cells/mL, is mixed with an equal volume of hemolytic antibody solution (anti-sheep erythrocyte antibody).

III) Procedure

Mix 0.30 mL of the sensitized cells and 0.45 mL of diluted samples. Incubate the reaction mixture at 37°C for 30 minutes. Each set of measurements should include the cell blank as well as the complete (100% lysis). At the end of the incubation period, 1.25 mL of cold TBS is added.

The tubes are centrifuged to remove unlysed cells, and the clear supernatant fluids are analyzed photometrically for hemoglobin at 550 nm. The 50% lytic dose of complement is read from a graph of log (y/l - y) against log x.

Hemolytic Total Complement Activity Assay Method Comparison

| Method | Mayer | Modified Mayer | Kent Fife | Modified Kent Fife |
|-------------------------|---|----------------|--|--|
| Erythrocyte | Sheep erythrocyte sensitized with antiserum | | Sheep erythrocyte sensitized with antiserum | |
| | 5 x 10 ⁸ /mL | | 5 x 10 ⁸ /mL | 2 x 10 ⁸ /mL |
| Buffer | GVB* ¹ pH 7.5 | | TBS* ² pH 7.35 | GVB pH 7.35 |
| Total volume | 7.5 mL | 3.0 mL | 2.0 mL | 0.1 mL |
| Reaction temperature | 37°C | | 37°C | |
| Reaction time | 60 min | | 30 min | |
| Measuring wavelength | 541 nm | | 550 nm | |
| | 38 ± 4 U/mL | | | 299 ± 128 U/mL |
| Definition of CH50 unit | The CH50 unit is defined as that amount in milliliters which will lyse 2.5 x 10 ⁸ optimally sensitized red cells out of a total of 5 x 10 ⁸ cells in one hour's incubation at 37°C in a total volume of 7.5 mL. | | The CH50 unit is the volume required to lyse half the cells in an aliquant (0.30 mL) of optimally sensitized erythrocytes in 30 minutes at 37°C. | The CH50 unit is defined as the reciprocal of the dilution of serum that lyses 50% of the cells in the assay. |
| Reference | Mayer, M.M. Complement and complement fixation. In: Kabat, E.A. and Mayer, M.M., Eds. Experimental Immunochemistry, 2nd Ed. Charles C Thomas, Springfield, IL, USA, 1967, 133 – 240. | | Kent, J.F., and Fife, E.H. Precise standardization of reagents for complement fixation. Am. J. Trop. Med. 12, 103 – 116 (1963). | Giclas, P. Protocol, "CH50 : Total hemolytic complement assay", National Jewish Center for Immunology and Respiratory Medicine, Denver, CO, USA. |

*1 Gelatin veronal buffer containing MgCl₂ and CaCl₂.

*2 Triethanolamine-buffered saline solution containing MgCl₂ and CaCl₂.

3. Liposome Immunoassay (LIA)⁴

(1) Liposomes

When lipids from biomembrane (phospholipids, cholesterol, etc.) are suspended in an aqueous solution, closed particles called liposomes are formed. Lipids constructing liposomes are characteristic substance which has a polar part (choline in phospholipid) and a nonpolar part (alkyl group in phospholipid). In an aqueous solution, the polar parts are hydrated and the nonpolar parts are collectively combined each other avoiding water. Thus, liposomes can envelop water-soluble substances (fluoresceners, enzymes, etc.) in the inner aqueous phase and fat-soluble substances in the lipid bilayer.

(2) Wako Autokit CH50 test

Wako developed an automated homogeneous liposome-based assay, Autokit CH50, which is a liposome immunoassay (LIA) reagent for the determination of total complement activity (CH50) in serum.

Principle of the LIA

When a sample is mixed with the reagent, complements in the sample are activated by the antigen-antibody complex on the liposomes. The activated complements break the membrane of the liposome. The enzyme, glucose-6-phosphate dehydrogenase (G6PDH) contained in the liposome, reacts with NAD and glucose-6-phosphate (G6P) in the reagent. During this enzyme reaction the NAD is reduced to NADH. As a result of this reduction, absorbance at 340 nm increases. The absorbance increase is proportional to the total complement activity (CH50) in the sample.

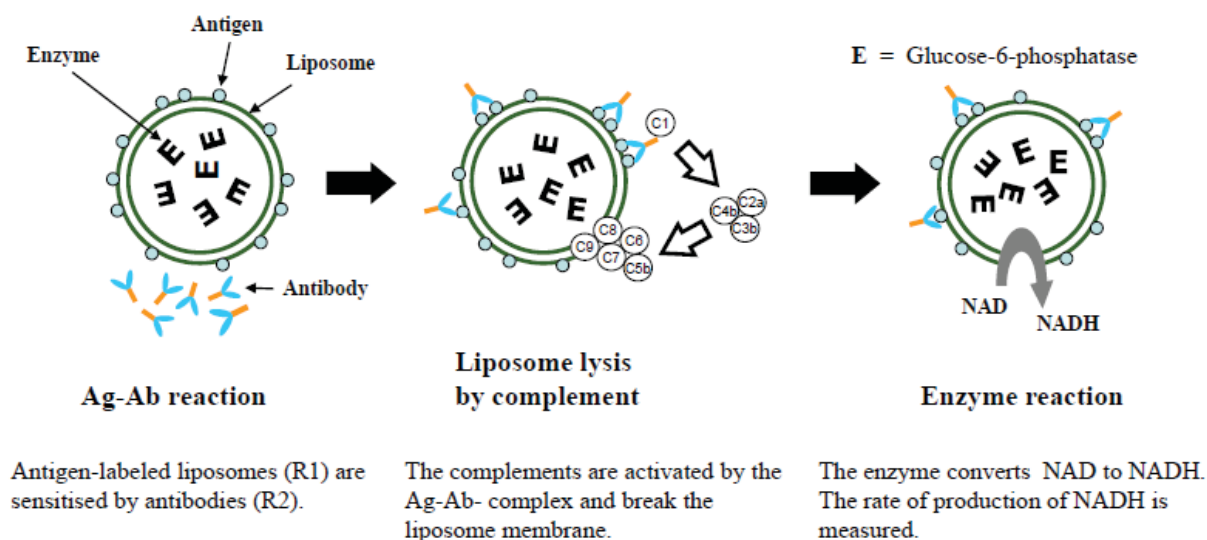

Fig. 8. Principle of liposome-based assay system.



Reagents

| Code No. | Product | Package | Storage |
|-----------|--------------------|---------------------------|----------------|
| 995-40801 | Autokit CH50 | R1: 2 x 20 mL | 2 – 10°C** |
| | | R2: 1 x for 20 mL | 2 – 10°C |
| | | R2a: 1 x 20 mL | 2 – 10°C |
| 997-43801 | CH50 Calibrator | CAL: 5 conc. x for 0,5 mL | -10°C or lower |
| 991-43701 | Complement Control | H: 10 x for 0,5 mL (High) | -10°C or lower |
| | | L: 10 x for 0,5 mL (Low) | -10°C or lower |

** Do not freeze.

Autokit CH50

R1: Liposome

2 bottles x 20 mL
Contains 4 units/mL
liposome containing G6PDH.

R2: Substrate

1 bottle x for 20 mL
Contains anti-DNP antibody, goat,
24 mmol/L G6P and 9 mmol/L NAD.

R2a: Diluent

1 bottle x 20 mL
Contains 10 mmol/L
maleate buffer, pH 5.0

CH50 Calibrator (5 conc. x for 0.5 mL)

| | |
|--------------|---------------------|
| Calibrator 1 | 1 vial x for 0.5 mL |
| Calibrator 2 | 1 vial x for 0.5 mL |
| Calibrator 3 | 1 vial x for 0.5 mL |
| Calibrator 4 | 1 vial x for 0.5 mL |
| Calibrator 5 | 1 vial x for 0.5 mL |

Contains human serum.

Complement Control

| | |
|----------------------|-----------------|
| Complement Control L | 10 x for 0.5 mL |
| Complement Control H | 10 x for 0.5 mL |

Contains human serum.

Determination of the assigned values of CH50 Calibrator and Complement Control is based on Mayer's method.

Reagent preparation

Reagent 1: (R1)

Use Liposome (1) as supplied. This solution is stable until expiration date.

Reagent 2: (R2) + (R2a)

Reconstitute one bottle (for 2.0 mL) of Substrate (2) with one bottle (20 mL) of Diluent (2a) to prepare the Substrate Solution. The Substrate Solution is stable for 40 days at 2 - 10°C.

Calibrator: (CAL)

Reconstitute one vial (for 0.5 mL) of each CH50 Calibrator with 0.5 mL of distilled or deionized water. Keep the reconstituted calibrator on ice or in a refrigerator* and use it within 8 hours.

Control: (CONTROL High / CONTROL Low)

Reconstitute one vial (for 0.5 mL) of each Complement Control with 0.5 mL of distilled or deionized water. Keep the reconstituted control on ice or in a refrigerator* and use it within 8 hours.

Saline solution:

Use saline solution for blank.

* If the solution is kept in a sample cup, cover the cup with a cap or film.

Warnings and precautions

- For *in vitro* diagnostic use only.
- The usage and application of this test is reserved for professional use only. Please refer to respective national and local regulations and legislation.
- Not to be used internally in humans and animals.
- Operate the instruments according to operator's manuals under appropriate conditions.
- Do not mix the reagents from one test unit with those of another test unit which has a different lot number.
- Do not use the containers and other materials in the package for any purposes other than those described herein.
- Clinical diagnosis must be determined with clinical symptoms and other test results by a physician.
- Store the reagents under the specified conditions. Do not use reagents past the expiration date stated on each reagent container label.
- Do not use reagents which were frozen in error. Such reagents may give false results.
- Since all specimens are potentially infectious, they should be handled with appropriate precaution. Refer to respective good laboratory practice protocols for preventing transmission of infection and handle samples in accordance with any other local or national regulations relating to the safe handling of such materials.
- Human serum material was used in the manufacture of CH50 Calibrator and Complement Control. The raw human serum used was tested and found negative for HBsAg, anti-HIV antibody and anti-HCV antibody. Because no test can offer complete assurance that products derived from human blood will not transmit infectious agents, it is recommended that CH50 Calibrator and Complement Control should be handled with the same biohazard precautions used for patient specimens.
- After opening the reagents, it is recommended to use them immediately. When the opened reagents are stored, cap the bottles and keep them under the specified conditions.
- If the reagents come in contact with the mouth, eyes or skin, wash off immediately with a large amount of water. Consult a physician if necessary.
- When discarding the reagents, dispose of them according to local or national regulations.
- Autokit CH50 (R2a) contains components classified as follows according to the European Directive 1999/ 45/ EC: mixture containing *5-chloro-2-methyl-2H-isothiazol-3-one* [EC No 247-500-7] and *2-methyl-2H-isothiazol-3-one* [EC No 220-239-6] (3:1).



Test procedure

Temperature: 37°C, Hitachi®917s

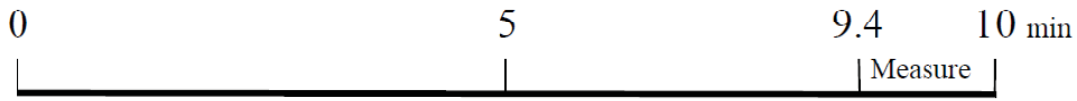

Sample: 6 μL

R1 (Liposomes) : 150 μL



R2 (Substrate) : 75 μL

λ Main: 340 nm

λ Sub: 700 nm

Performance

Reaction time course Hitachi®917s

In the hemolytic method, erythrocytes are antibody-sensitized. Our liposomes are not antibody sensitized but reacted with antibody in the reaction mixture. We studied the reaction, of the liposomes and antibody. Fig. 9 depicts a typical reaction course of the liposome-based assay for total complement activity. Immediately after the addition of Reagent 2, the liposomes were completely sensitized by the antibody in the reaction mixture. Constant enzyme activity was observed from 4.4 to 5 min after the addition of Reagent 2.

In our assay, absorbance at 340 nm was measured from 4.4 to 5 min after the addition of Reagent 2.

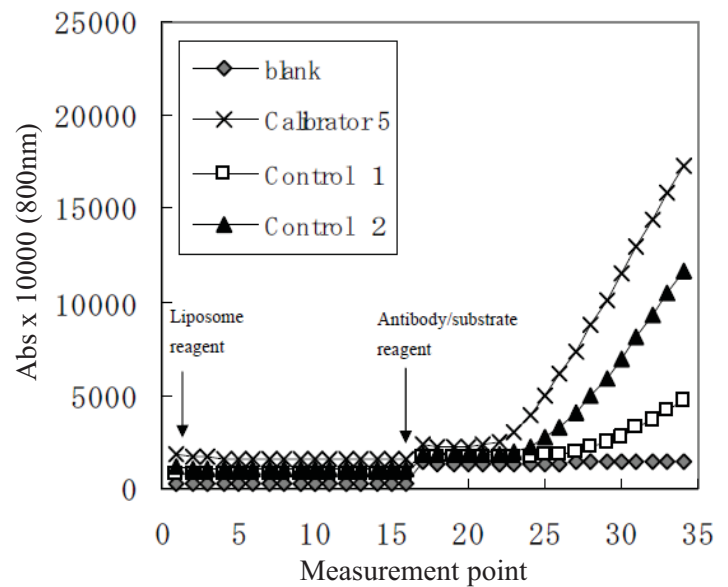

Fig. 9. Reaction time course of liposome-based assay system. Each 6 mL of human sera with complement activity of 43 (x), 39 (o) or 0 (+) and 150 μL of Reagent 1 were mixed. After 5 min, 75 μL of Reagent 2 was added.



Precision

Preliminary precision test (Within-run precision)

| Run# | Sample# | Replicates | Mean (U/mL) | SD | SV (%) |
|------|---------|------------|-------------|-----|--------|
| 1 | 1 | 21 | 49.5 | 0.5 | 1.01 |
| 1 | 2 | 21 | 25.9 | 0.3 | 1.35 |
| 2 | 1 | 21 | 46.2 | 0.5 | 1.14 |
| 2 | 2 | 21 | 27.9 | 0.3 | 1.05 |

Total precision (Between-run precision)

Two levels of controls were run in duplicate and in duplicate runs for a period of 21 days. The data was collected according to NCCLS Guidelines.

| Concentration Level | # of assay Days | Mean (U/mL) | CD | SV (%) | S _{wr} | S _T |
|---------------------|-----------------|-------------|------|--------|-----------------|----------------|
| High | 21 | 48.3 | 1.57 | 3.2 | 18.9 | 22.1 |
| Low | 21 | 26.9 | 1.54 | 5.7 | 16.6 | 16.7 |

Correlation (Accuracy)

Correlation of total complement activity between Mayer’s method and Wako Autokit CH50. The results from the liposome-based assay correlated well with those from the Mayer’s method. We compared our liposome-based assay with the Mayer’s method (Fig. 10).

Dilution tests (Linearity)

Two human serum samples were diluted with saline and assayed. (Fig. 11)

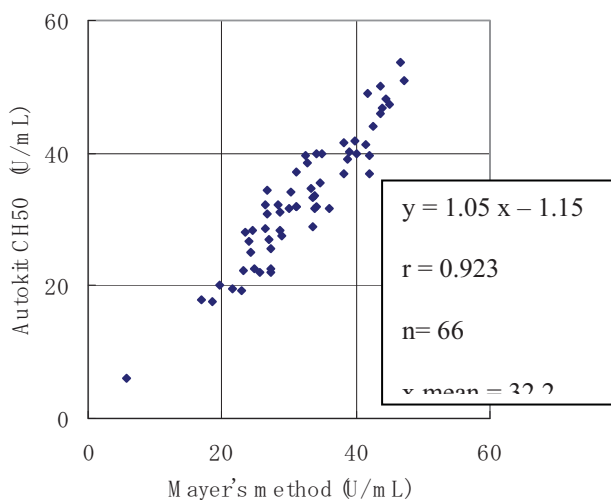

Fig. 10. Correlation of total complement activity between Mayer’s method and Wako Autokit CH50.

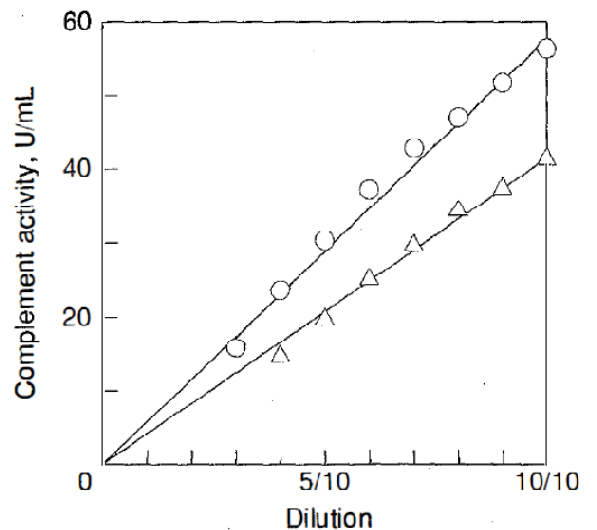

Fig. 11. Dilution tests. Two human samples, one with normal (Δ) and the other with high (O) complement activity, were diluted serially with saline and assayed as described in the text.



Sensitivity

The minimum detectable CH50 is estimated to be 4.0 U/mL on Hitachi®917s (Fig. 12).

This was defined as the lowest concentration where the mean value minus 2SD was greater than the mean value plus 2SD of an analyte-free sample, when they were measured 10 times, respectively.

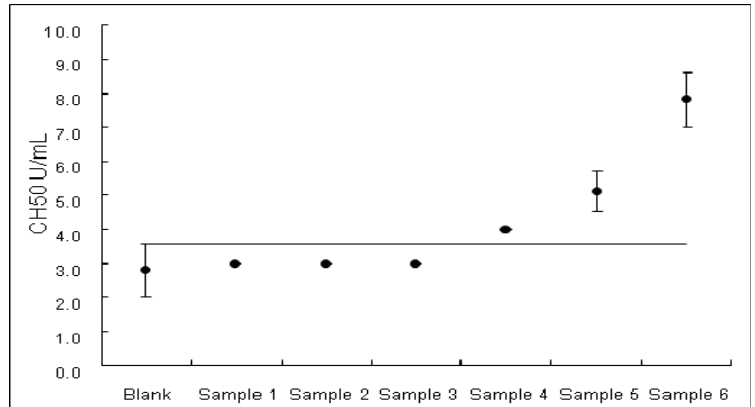

Fig. 12. Minimum detectable level of CH50.

Calibration (Reagent stability)

Autokit CH50 Reagent stability after preparation initial was investigated on Hitachi 717 for 48 days. The first set of runs was performed according to a protocol where the calibration was done only on the first day.

The second set of runs was performed according to another protocol where the calibration was done on each day. As shown in the following data, the reconstituted reagent (R2) was stable for 48 days. The calibration is not necessary for at least 48 days when the reagent from the same bottle is used.

1st set of runs. Calibrated only on the first day (Day 0).

| Days | CH50 (U/mL) | | |
|-------|-------------|----------|----------|
| | Sample 1 | Sample 2 | Sample 3 |
| 0 | 29.3 | 19.3 | 50.6 |
| 3 | 31.8 | 20.2 | 51.1 |
| 5 | 30.1 | 20.0 | 50.8 |
| 7 | 28.1 | 19.7 | 49.5 |
| 14 | 29.8 | 19.6 | 49.8 |
| 20 | 29.3 | 19.7 | 49.9 |
| 31 | 29.5 | 18.9 | 50.5 |
| 38 | 30.1 | 19.9 | 51.2 |
| 48 | 32.6 | 20.8 | 52.0 |
| Max | 32.6 | 20.8 | 52.0 |
| Min | 28.1 | 18.9 | 49.5 |
| Mean | 30.07 | 19.79 | 50.60 |
| SD | 1.285 | 0.509 | 0.742 |
| CV(%) | 4.3 | 2.6 | 1.5 |

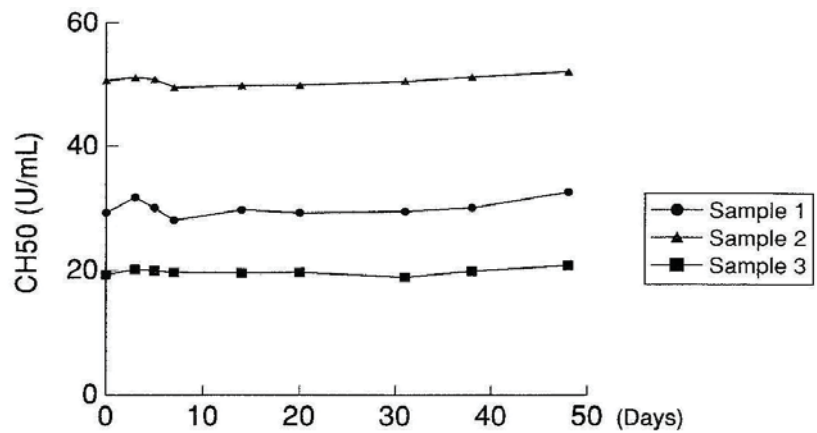

2nd set of runs. Calibrated on each day.

| Days | CH50 (U/mL) | | |
|-------|-------------|----------|----------|
| | Sample 1 | Sample 2 | Sample 3 |
| 0 | 29.3 | 19.3 | 50.6 |
| 3 | 32.3 | 20.1 | 51.0 |
| 5 | 30.2 | 19.7 | 50.7 |
| 7 | 30.1 | 21.0 | 51.5 |
| 14 | 30.4 | 20.1 | 53.0 |
| 20 | 30.2 | 19.9 | 52.3 |
| 31 | 32.2 | 20.4 | 52.6 |
| 38 | 31.5 | 20.5 | 53.0 |
| 48 | 31.6 | 20.4 | 50.0 |
| Max | 32.3 | 21.0 | 53.0 |
| Min | 29.3 | 19.3 | 50.0 |
| Mean | 30.87 | 20.16 | 51.63 |
| SD | 0.996 | 0.467 | 1.061 |
| CV(%) | 3.2 | 2.3 | 2.1 |

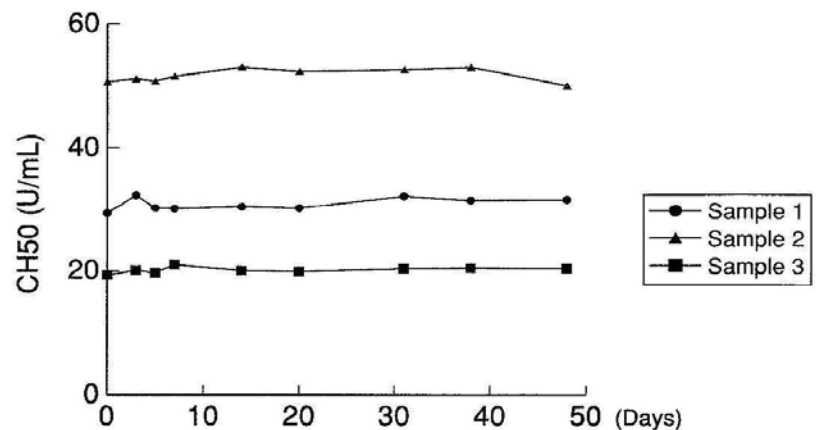



Interference studies (Specificity)

We studied the effects of ascorbic acid, bilirubin, and hemoglobin on this assay system. Ascorbic acid concentrations up to 50 mg/dL, bilirubin concentrations up to 40 mg/dL and hemoglobin concentrations up to 500 mg/dL do not interfere with this system.

Hemoglobin, ascorbic acid, bilirubin, intrafat or rheumatoid factor does not have a significant influence on the assay.

| | | | | | | | |
|------------------|---------|------|------|------|------|------|------|
| Ascorbic acid | (mg/dL) | None | 10 | 20 | 30 | 40 | 50 |
| CH50 | (U/mL) | 38.7 | 38.9 | 38.6 | 38.7 | 38.5 | 38.2 |
| Hemoglobin | (mg/dL) | None | 100 | 200 | 300 | 400 | 500 |
| CH50 | (U/mL) | 41.4 | 40.9 | 40.2 | 40.2 | 40.8 | 40.2 |
| F-Bilirubin | (mg/dL) | None | 8 | 16 | 24 | 32 | 40 |
| CH50 | (U/mL) | 31.8 | 31.9 | 32.4 | 31.3 | 32.6 | 33.1 |
| C-Bilirubin | (mg/dL) | None | 8 | 16 | 24 | 32 | 40 |
| CH50 | (U/mL) | 31.2 | 31.5 | 31.4 | 31.0 | 31.1 | 31.1 |
| Intrafat | (%) | None | 0.6 | 1.2 | 1.8 | 2.4 | 3.0 |
| CH50 | (U/mL) | 42.4 | 42.4 | 42.3 | 42.4 | 42.6 | 42.1 |
| Reumatoid factor | (IU/mL) | None | 90 | 180 | 270 | 360 | 450 |
| CH50 | (U/mL) | 35.7 | 35.4 | 35.2 | 34.9 | 34.3 | 33.6 |



4. Specimen

Serum is used as a specimen for the CH50 test. Complements are heat-labile. Complement activity in a specimen gradually decreases while the specimen is left at room temperature. Measure the complement activity immediately after separation of serum. If a specimen needs to be stored, keep it at -20°C for up to one week or -40°C for up to one month. If longer storage is necessary, keep it at -70°C or lower. The sample should be thawed slowly on an ice bath.

Warning/Biohazard

Since all specimens are potentially infectious, they should be handled with appropriate precaution. Refer to respective good laboratory practice protocols for preventing transmission of infection and handle samples in accordance with any other local or national regulations relating to the safe handling of such materials.

5. Cold Activation⁵

After blood collection, if coagulation, serum separation and storage are done at refrigerated temperature, certain sera show decrease of total complement activity, while the sera obtained from the same blood allowed clotting at 37°C show normal values. In those cases the complement system is activated *in vitro*. This phenomenon has often been reported as cold activation of complement in patients with chronic liver diseases, primary renal diseases, and systemic lupus erythematosus. Relationship between the cold activation and cryoglobulinemia has also been reported. If the patient is suspected or known to have a cryoglobulin, it is recommended that the CH50 test should be done as soon as possible after the serum is obtained and never chill the serum.

D. Clinical Significance¹

Serum complement activity increases or decreases with various diseases such as autoimmune diseases, infectious diseases, liver diseases, cancers. It is recommended to measure the serum complement activity for patients who carry or are suspected to carry the diseases shown in the following table.

| Total complement activity | Diseases |
|---------------------------|---|
| Reduced | <ul style="list-style-type: none"> • Systemic lupus erythematosus (SLE) • Malignant rheumatoid arthritis • Juvenile rheumatoid arthritis • Autoimmune hemolytic anemia • Serum sickness • Hereditary angioneurotic edema • Acquired C3 deficiency • Disseminated intravascular coagulation (DIC) • Cryoglobulinemia • Felty's syndrome • Malaria • Membranoproliferative glomerulonephritis (MPGN) • Acute glomerulonephritis • Endotoxin shock • Partial lipodystrophy • Hemodialysis • Factor I deficiency • Cirrhosis • Fulminant hepatitis • Hereditary complement deficiencies |
| Elevated | <ul style="list-style-type: none"> • Chronic rheumatoid arthritis • Malignant tumor • Acute and chronic infection • Polyarteritis • Behcet's disease • Systemic sclerosis • Dermatomyositis • Sarcoidosis • Wegener's granulomatosis • Multiple myeloma • Reiter's syndrome |

1. Reduced Total Complement Activity

Hereditary complement deficiencies

The typical cases showing reduced total complement activity are hereditary complement deficiencies. Total complement activity in the deficiencies is extremely low or lower than the detectable level. Heterozygous deficiencies usually result in plasma levels of the component of about one-half the normal value, and do not, as a rule, cause any disease. Homozygous deficiencies have been recognized for almost all the complement components. All the deficiencies are relatively rare, and the incidence varies greatly between different ethnic groups. In the caucasian population C2 deficiency is the most common. Whereas, in the Japanese population by far the most common is the deficiency of C9, which is very rare in other racial groups. Homozygous deficiencies are often, though not always, associated with disease. Disease associations of the known deficiencies are pyogenic infection, systemic lupus erythematosus (SLE), glomerulonephritis, etc. Deficiencies of complement components should be considered in patients with autoimmune diseases such as SLE and membranoproliferative glomerulonephritis, and in patients with a history of repeated infection. Suspicion should be heightened if either or both of these disease groups are present in several members of a family.

Immune-complex-mediated diseases

In immune-complex-mediated diseases, caused by excess immune reactions such as autoimmune diseases, the complement cascade is chronically activated by the immune complex and complement components are consumed resulting in reduced total complement activity. The typical immune-complex-mediated diseases are SLE, glomerulonephritis, autoimmune hemolytic anemia, etc. Serum total complement activity (CH50) and the levels of complement components are reduced secondary to chronic activation by immune complexes, the extent of this reduction mirroring disease activity. Measurement of complement activation, therefore, provides important clinical information on the course of disease and its response to therapy.

Systemic lupus erythematosus (SLE)

SLE is a chronic, non-organ-specific autoimmune disease affecting primarily the kidneys, joints and skin, although other organs are often involved. Complement has been implicated in the pathogenesis of tissue damage in many diverse organs in this disease. SLE usually presents in young adults. It is 5 - 10 times more common in women than in men. The typical clinical presentation includes fever, weight loss, arthralgia, a characteristic butterfly rash and nephritis, although many individuals present with very atypical symptoms. Serologically, the disease is associated with the presence of circulating autoantibodies and immune complexes. In most instances, the initiation of organ damage can be attributed to the deposition of immune complexes in the tissues.

Renal diseases

The most common manifestation of immune complex disease is nephritis. Most nephritides are characterized by all inflammatory reaction, within the glomerulus, accompanied by leucocyte infiltration and cellular proliferation. However, in some forms of nephritis cellular infiltration and proliferation are minimal or even absent. The underlying cause of most nephritides is an antigen-antibody reaction. This reaction may be localized in the glomerulus, antiglomerular antibodies recognizing their target antigen in the tissue, or it may occur remote from the kidney, with subsequent deposition in the glomerulus of immune complexes formed elsewhere in the circulation. In either case, antibody immobilized in the glomerulus will initiate inflammation by activating complement and recruiting inflammatory cells. The importance of complement is to maintain immune complexes in a soluble state. Thus, under different circumstances complement activation can be protective or pathological. Complement protects against immune complex deposition in the kidney by maintaining complexes in solution. If, however, complexes are formed *in situ*, or are deposited despite solubilization, complement activation within the kidney contributes to inflammation and tissue damage.

Autoimmune hemolytic anemia

A group of autoimmune hemolytic anemia is caused by antibodies which bind optimally to the erythrocyte at low temperatures (cold-reacting antibodies). These antibodies bind to erythrocytes in the peripheral circulation, where if the external environment is cold the blood temperature may fall to around 37°C, and dissociate on rewarming to 37°C. These antibodies activate complement via the classical pathway very efficiently, and therefore, cause lysis of a significant proportion of attacked erythrocytes.

Liver diseases

Liver is the major source of most of the complement components. Reduced total complement activity is observed with liver diseases such as chronic hepatitis and cirrhosis due to complement production failure.

Malignant rheumatoid arthritis

Although most rheumatoid arthritis patients have normal or elevated serum complement levels, in acute exacerbated cases, reduced serum complement levels are observed.

2. Elevated Total Complement Activity

Bacterial infection

Neutralization and removal of invading organisms constitute the major biological role of the complement system. Serum complement, though capable of lysing directly only a few strains of bacteria, enhances phagocytosis of many other strains - the process of opsonization. The complement system, either alone or in concert with other components of the immune system, eliminates bacteria, viruses, fungi and other invading organisms. Acute, severe viral infections are often accompanied by marked systemic complement activation.

Rheumatoid arthritis

Rheumatoid arthritis (RA) is a common chronic inflammatory disease of unknown etiology which affects principally the joints. Although there is abundant evidence implicating complement activation in RA, systemic hypocomplementaemia is not a common feature, most patients having normal or even elevated serum complement levels. This finding is a consequence of the localized nature of inflammation in RA, increased consumption in the joint being compensated - or overcompensated - for by increased synthesis. Diminished serum complement levels are occasionally found during acute exacerbations of the disease when demand temporarily outstrips supply. In the synovial fluid, complement activity is usually reduced, reflecting the intense local activation.

References

1. Morgan, B. P. Complement. Academic Press, London, UK, 1990.
2. Mayer, M. M. Complement and complement fixation. In: Kabat, E A. and Mayer, M. M., Eds. Experimental Immunochemistry, 2nd Ed. Charles C Thomas, Springfield, IL, USA, 1967, 133 - 240.
3. Kent, J. F. and Fife; E. H. Precise standardization of reagents for complement fixation. Am. J. Trop. Med. **12**, 103 - 116 (1963).
4. Yamamoto, S., Kubotsu, K, Kida, M., Kondo, K., Matsuura, S., Uchiyama, S., Yonekawa, O. and Kanno, T. Automated homogeneous liposome-based assay system for total complement activity. Clin. Chem., **41**, 586 - 590 (1995).
5. Takemura, S., Hotta, T., Matsumura, N., Yoshikawa, T. and Kundo, M. Cold activation of complement. Arthritis Rheum., **25**, 1138 - 1140 (1982).

Manufactured by/ Distributed by:

Wako Pure Chemical Industries, Ltd.

1-2 Doshomachi 3-Chome, Chuo-Ku, Osaka 540-8605, Japan

Telephone: + 81-6-6203-3741

Facsimile: + 81-6-6222-1203

www.wako-chem.co.jp

Wako Chemicals USA, Inc.

1600 Bellwood Road

Richmond, VA 23237, USA

Telephone: + 1-804-271-7677

Facsimile: + 1-804-271-7791

www.wakousa.com

Wako Chemicals GmbH

Fuggerstraße 12

D-41468 Neuss, **Germany**

Telephone: + 49-2131-311-0

Facsimile: + 49-2131-311-100

www.wako-chemicals.de